

## SCA30 Series For working pressure up to 3000 psig(206bar)

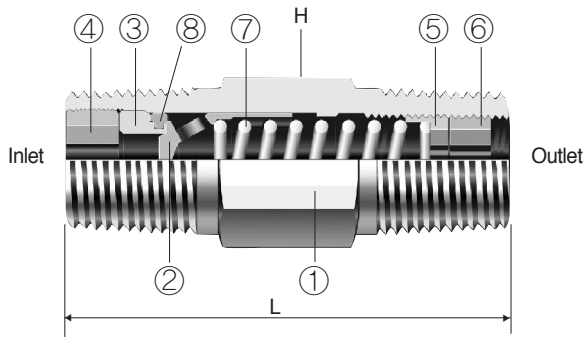

### Materials of Construction

Item	Description	Valve Body Materials	
		S316	Brass
1	Body	S316 /A276, A479	Brass
2	Poppet		
3	Insert		
4	Insert Lock Screw		
5	Adjusting Screw		
6	Locking Screw		
7	Spring	S302/A313	
8	O-ring	Viton	NBR

\*Silicone-based Lubricant for poppet.  
Wetted parts are listed in orange color.

### Features

- Pressure rating up to 3,000psig (206bar) @ 70°F (21°C).
- Temperature rating up to 375°F (191°C) with Standard Viton O-ring.
- Choice of materials : Standard S316 and Brass.
- Cracking pressures include : 1/3, 1, 3, 10, 25, 50psi.
- Heat code traceability.
- Every valve is 100% factory tested for cracking and reseal.

### • Spring Cracking Pressure Range Designator

Designator	Cracking Pressure	
	psi	bar
3	3 to 50	0.21 to 3.5
5	50 to 150	3.5 to 10.4
150	150 to 350	10.4 to 24.2
350	350 to 600	24.2 to 41.4

### Ordering Information and Dimensions

Basic Ordering Number	Cv	End Connections			Dimensions mm (inch)		
		Size	Inlet	Outlet	L	H	
SCA1	F-4N	0.35	1/4"	Female NPT		75.7(2.98)	3 / 4
	M-4N		1/4"	Male NPT		41.1(1.62)	9 / 16
	M-4R		1/4"	Male BSPT		41.1(1.62)	9 / 16
SCA2	M-8N	1.20	1/2"	Male NPT		65.0(2.56)	7 / 8
	M-8R		1/2"	Male BSPT		65.0(2.56)	7 / 8

To order, add a cracking pressure range designator to the basic ordering number and then specify valve material designator.  
Example : SCA1-M-4N-3-S6